

TROLLEY JACK

PREMIUM SERIES

BR-2TP



• Round handle

• Spare Parts Tray with Magnet

• Nylon Wheel

• Foot Pedal

ITEM NO	CAPACITY	MIN HEIGHT	MAX HEIGHT	WEIGHT	PACKING SIZE
BR-2TP	2 TON	75MM	500MM	37.5KGS	95x38x20cm

BR-2TP

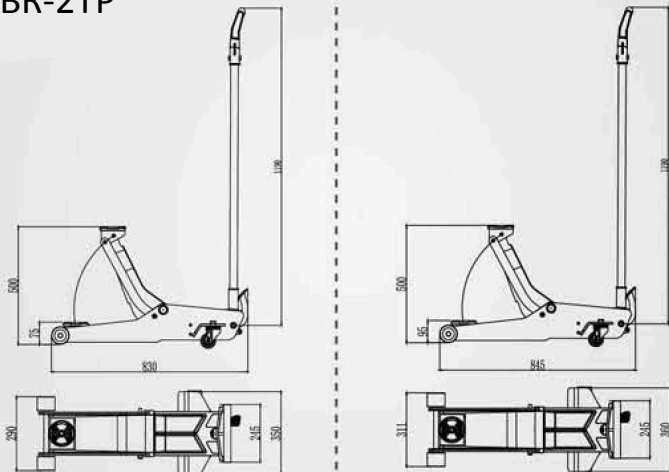

Features

- Hold to run
- Nylon wheels
- Designed handle
- Designed locking
- Two speed action
- Dead-man Principle
- Safe locking system
- Designed spare parts tray
- Foot pedal with rubber pad for fast lifting
- Sand blasting and wrinkle painting
- Hard chrome plated rod and special sealing construction of pump

TROLLEY JACK

KING SERIES

BR-2TK

BR-3TK



ITEM NO	CAPACITY	MIN HEIGHT	MAX HEIGHT	WEIGHT	PACKING SIZE
BR-2TK	2 TON	75MM	500MM	36KGS	111x38x20cm
BR-3TK	3 TON	95MM	500MM	40.5KGS	111x38x20cm

BR-2TK

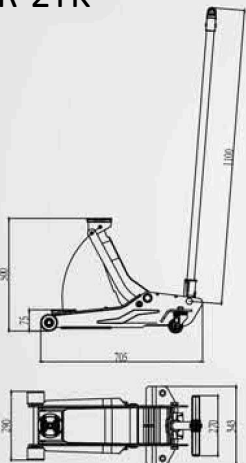

BR-3TK

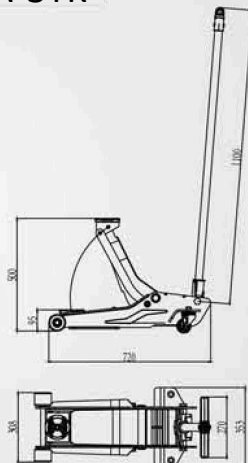

Features

- Hold to run
- Designed handle
- Designed looking
- Two speed action
- Dead-man Principle
- Sand blasting and wrinkle painting
- Designed spare parts tray
- Foot pedal with rubber pad for fast lifting;
- Nylon wheels
- Hard chrome plated rod and special sealing construction of pump

BR-302A

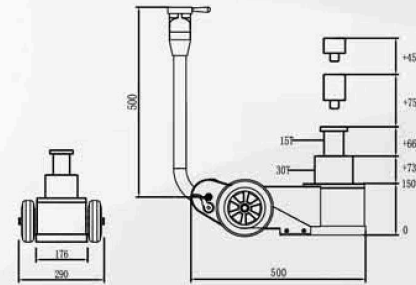

Features

- Slow down valve.
- Safety overload valve.
- Oil anti-back system.
- Hard chrome plated both internal & external cylinder.
- XTP industry sealing(double sealing function).
- Imported sealing from USA.
- Self-return switch for safe working.
- Only 24kgs weight with 30T/15T capacity for portable service.
- Ergonomic handle design with 4 positions for lifting, carrying, moving.

Model	Capacity	Working air pressure	Min Height	Max Height	Lifting Height	Extension Height	Net Weight
BR-30-2A	30T/15T	0.8-1.2Mpa	150mm	409mm	30T:73mm 15T:66mm	75mm+45mm	24kg

BR-60-3A

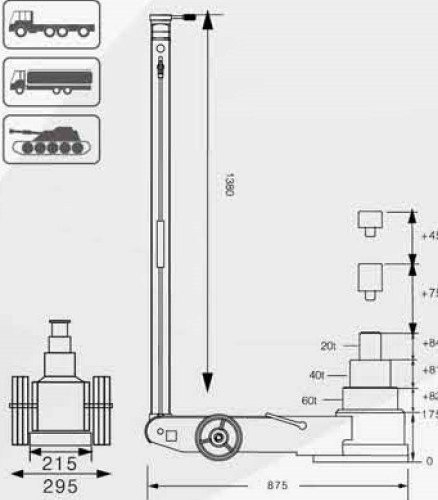

Model	Capacity	Working air pressure	Min Height	Max Height	Lifting Height	Extension Height	Net Weight
BR-60-3A	60T/40T/20T	0.8-1.2Mpa	175mm	542mm	60T:82mm 40T:81mm 20T:84mm	75mm+45mm	73kg

Features

- Slow down valve.
- Safety overload valve.
- Oil anti-back system.
- Imported sealing from USA.
- Self-return switch for safe working.
- Hard chrome plated both internal & external cylinder.
- XTP industry sealing(double sealing function).

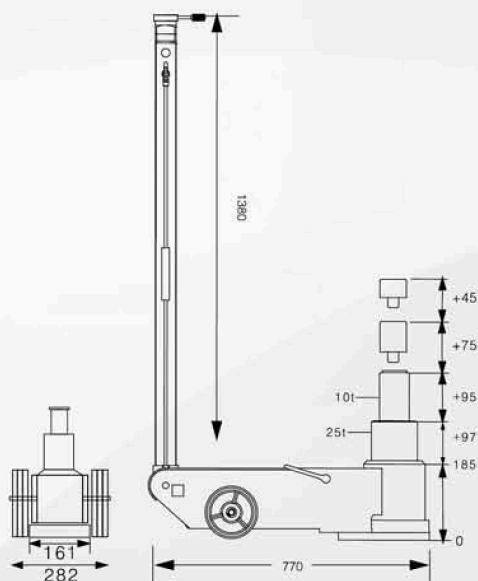
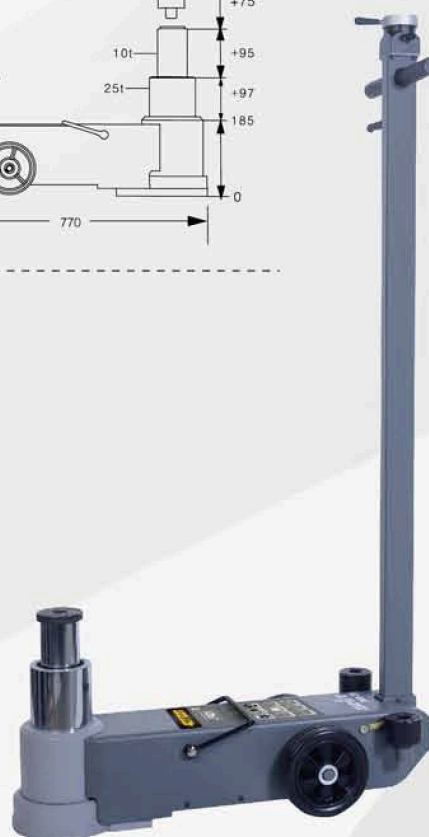
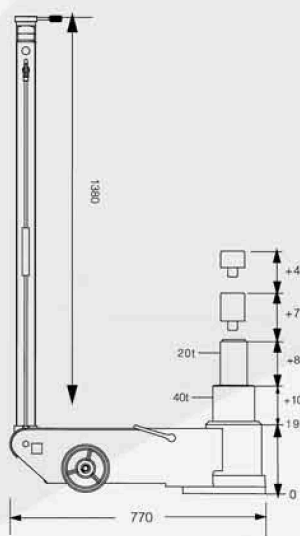
BR**BR-25-2A****BR-40-2A**

Model	Capacity	Working air pressure	Min Height	Max Height	Lifting Height	Extension Height	Net Weight
BR-25-2A	25T/10T	0.8-1.2Mpa	185mm	497mm	25T:97mm 10T:95mm	75mm+45mm	53kg
BR-40-2A	40T/20T	0.8-1.2Mpa	190mm	504mm	40T:106mm 20T:88mm	75mm+45mm	62kg

Features

- Slow down valve.
- Imported sealing from USA.
- Hard chrome plated both internal & external cylinder.
- XTP industry sealing(double sealing function).
- Safety overload valve.
- Self-return switch for safe working.
- Oil anti-back system.

BR-40-3A

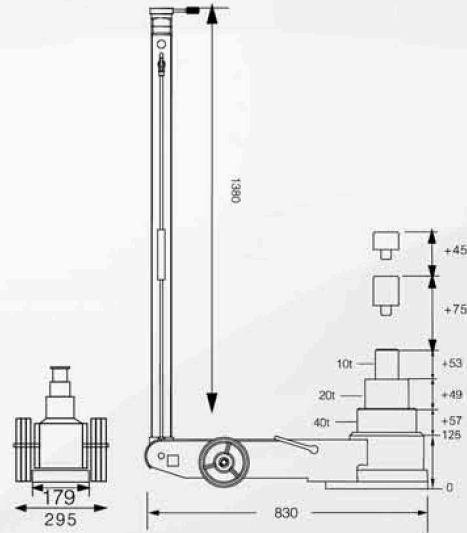

BR-50-3A

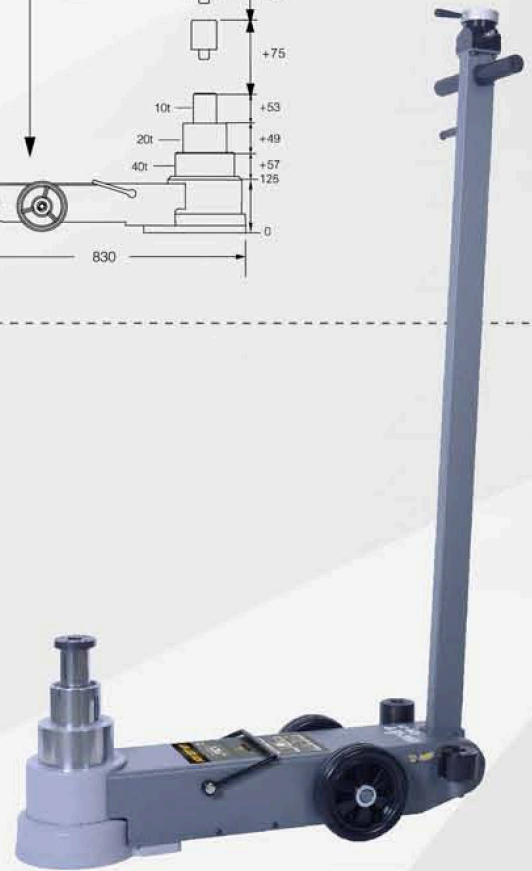
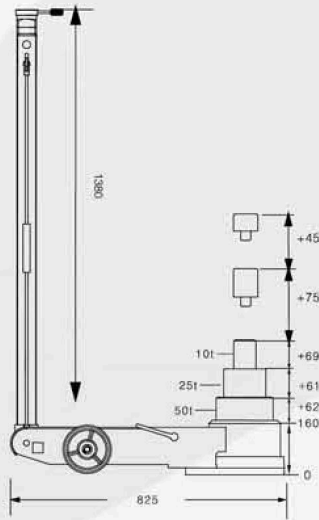

Model	Capacity	Working air pressure	Min Height	Max Height	Lifting Height	Extension Height	Net Weight
BR-40-3A	40T/20T/10T	0.8-1.2Mpa	125mm	404mm	40T:57mm 20T:49mm 10T:53mm	75mm+45mm	44kg
BR-50-3A	50T/25T/10T	0.8-1.2Mpa	160mm	472mm	50T:62mm 25T:61mm 10T:69mm	75mm+45mm	61kg

Features

- Slow down valve.
- Imported sealing from USA.
- Hard chrome plated both internal & external cylinder.
- XTP industry sealing(double sealing function).
- Safety overload valve.
- Self-return switch for safe working.
- Oil anti-back system.

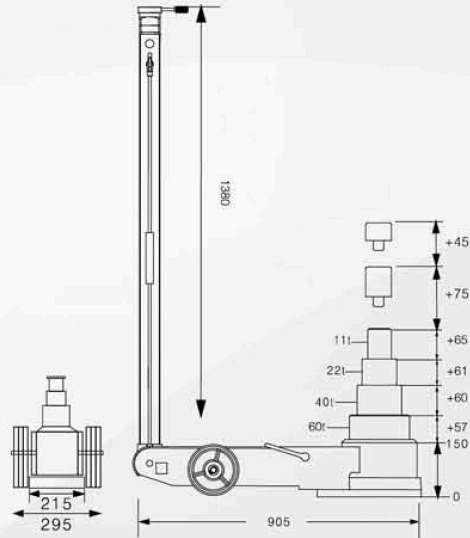
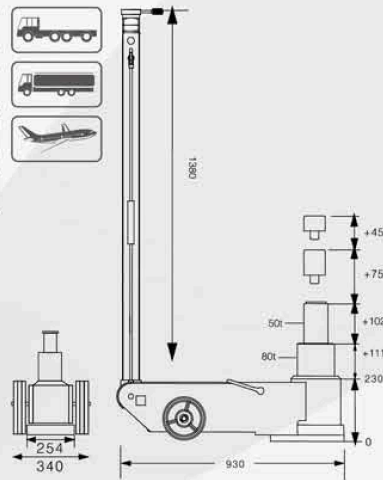
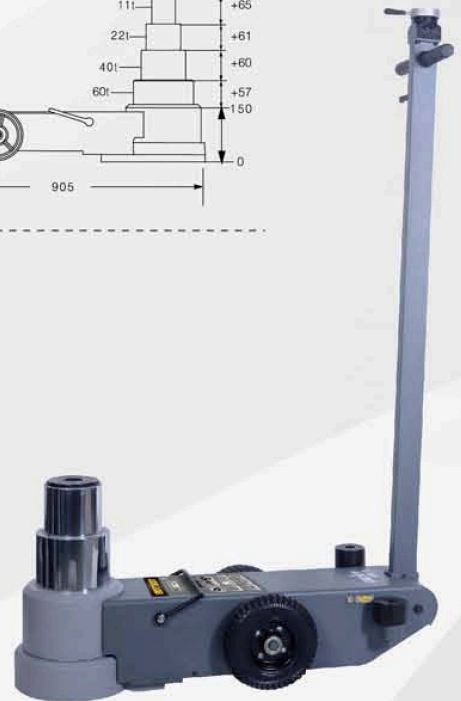
BR**BR-60-4A****BR-80-2A**

Model	Capacity	Working air pressure	Min Height	Max Height	Lifting Height	Extension Height	Net Weight
BR-60-4A	60T/40T/ 22T/11T	0.8-1.2Mpa	150mm	513mm	60T:57mm 40T:60mm 22T:61mm 11T:65mm	75mm+45mm	66kg
BR-80-2A	80T/50T	0.8-1.2Mpa	230mm	563mm	80T:111mm 50T:102mm	75mm+45mm	106kg

Features

- Slow down valve.
- Imported sealing from USA.
- Hard chrome plated both internal & external cylinder.
- XTP industry sealing(double sealing function).
- Safety overload valve.
- Self-return switch for safe working.
- Oil anti-back system.